



MTSD-3

Two-Tone Decoder

Manual Revision: 2010-08-27

Hardware Revision(s): 165C

SPECIFICATIONS

Operating Voltage	6-24 VDC
Operating Current	6 mA
Input Level	10 mV – 1 V RMS 15 mV – 1.4 V P-P
Input Impedance	100 K
Frequency Range	
MTSD-3A	280 – 1600 Hz
MTSD-3B	500 – 2800 Hz
Ring Output	2400 Hz
Momentary Output	200 mA
Latched Output	200 mA
PTT Transpond Current	100 mA
Min. Tone Time	150 – 2500 ms
Inter Tone Time	0 – 250 ms
Operating Temperature	-30°C - +60°C
Dimensions	.94"W x .32"H x 1.9"L

GENERAL INFORMATION

The MTSD-3 is a 2-Tone decoder that is available in 2 different frequency ranges. Two units can be combined and have the outputs “anded” together to do two plus two type 2-Tone decoding (see Technical Notes section for details).

CIRCUIT DESCRIPTION

The signal is fed into the MTSD-3 via the orange lead and is amplified by U1A. The value of “R Limit” may be adjusted by the customer to adapt the audio signal available into the customer’s radio. This range, from 10 mV to 1 V RMS, is shown on the input level chart on the schematic.

Frequencies A and B are selected by the circuitry of U1B, U1C and U1D. The selected frequency from U1C Pin 14 band-pass output is fed to U2A, where it is detected, and the DC is then passed on to the Schmidt trigger U2B. The output of the Schmidt comparator (pin 14) is fed to the timing circuitry of U3A through U3E. U3F is the 2400 Hz alert tone oscillator and is held off by a low from U3E until decoding. Upon decoding, the output of U3E is also sent to U2C, and the resulting high output of U2C produces drive to transistor Q4. The output of Q4 is normally high, and the Call (white) lead and the Positive Squelch (green/white) lead outputs will reflect this high until decoding occurs. Upon decoding, the Positive Squelch floats, and the call output goes low. Inverter Q5 is driven by Q4, and its output, Negative Squelch (yellow) lead, goes from a low to a float upon decoding.

Two monitor inputs that will open the radio squelch and turn on the call light are also available. Monitor 2, upon going high, will activate the squelch outputs (outputs will not reset when the high is removed). When Monitor 1 is used, a low input is normally placed on the input, and when it is removed (floats), the squelch outputs will be activated. Returning Monitor 1 to a low will reset the squelch outputs. Note: Monitor 1 must be held low via JU2 when Monitor 1 is not used.

The Transpond Low (PTT) output is activated for approximately 1 second, when decode occurs, via the high output of U3E, U2D and Q6.

U3E goes high for 3 seconds after decode and drives Q3’s output (gray) low assuming it is pulled up to 12 V via a horn relay.

The MTSD-3 employs a 5V regulator to assure consistent operation over the wide range of input voltages.

HARDWARE INSTALLATION

Be certain to follow standard anti-static procedures when handling any of Midian's products.

P1-1 – Green – Transpond Output – Connect to the PTT switch of the radio.

P1-2 – Red – +VIN – Connect to switched B+ in the radio.

P1-4 – Black – Ground – Connect to the nearest ground point in the radio.

P1-5 – Blue – Alert Tone Output – Connect to a low impedance point in the modulator circuit. For high impedance use P1-13. Momentary (3 second) 2400 Hz output.

P1-6 – Orange – Tone Input – Connect to an unswitched audio point in the receiver.

P1-7 – Yellow – Negative Squelch – Connect to the proper squelch clamp point in the receiver. This output is low before decoding. Upon decoding, it latches to a float state.

P1-8 – Green/White – Positive Squelch – Connect to the proper squelch clamp point in the receiver. This output is high before decoding. Upon decoding, it loses its high and latches to a float state because of D9.

P1-9 – White – Call Output – Latched low output. Use for call LED. Use a current-limiting resistor.

P1-10 – Gray/White – Horn Output – Momentary (3 second) open collector to ground output upon decoding.

P1-11 – Gray – Monitor 1 Input – This input is used with an external monitor switch that is normally closed to ground. When the ground is released OP amp U2-C will release the Squelch outputs allowing the channel to be monitored. Placing the switch back to ground will cause OP amp U2-C to latch and turn off the Squelch outputs. If this is not used, ground JU-2 or the gray wire.

P1-12 – Orange/White – Monitor 2 Input – Connect to a point in the transmitter that goes high when PTT is tapped or depressed. This will unlatch U2-C and the squelch outputs for channel monitoring. When finished with the conversation cycle the power to the unit to reset U2-C and the squelch outputs. If using this input, JU-2 or the gray wire must be grounded.

P1-13 – Violet – Alert Out Hi Z - Connect to the modulator circuit. Use high impedance point in the radio. If generating CTCSS, use the CTCSS point in the modulator. For low impedance use P1-5.

PRODUCT PROGRAMMING

A Tone: Encode the desired A tone to the MTSD-3 at 0.5 to 1.0 V p-p while monitoring TP2 with an oscilloscope. Turn the pot R-12 until maximum amplitude is obtained. If the pot is turned past the peak then the tone will drop out. Turn the pot the reverse direction to get the tone back. JU1 should not be installed during the setting of the A tone. Once aligned cycle the power to the unit and recheck to make certain the amplitude is at maximum.

B Tone: Install JU1 on the MTSD-3. Encode the desired B tone to the MTSD-3 at 0.5 to 1.0 V p-p while monitoring TP2 with an oscilloscope. Turn the pot R-11 until maximum amplitude is obtained. If the pot is turned past the peak then the tone will drop out. Turn the pot the reverse direction to get the tone back. Once aligned cycle the power to the unit and recheck to make certain the amplitude is at maximum. Remove JU1 when finished.

Long Tone Group Call: Long tone group call can be accomplished by sending 4 seconds of the programmed A tone, or by programming the A tone and the B tone for the same frequency. This product is not compatible with Long B tone decode.

HARDWARE ALIGNMENT

Bandwidth: If tones A and B are close to one another it may be necessary to narrow the bandwidth of the decoder by adjusting R-21. With JU1 uninstalled and generating the B tone to the decoder, adjust R-21 to where U2 Pin 8 does not change from low to high.

Audio Input Level: If there is not enough level going into the decoder it may be necessary to reduce the value of R-5.

Momentary Output Time: The MTSD-3 gives a 3 second momentary output by default. To increase this time increase the value of C-9 or decrease the value of R-31 to decrease the time. Please note that this will also affect the timing of the transpond timing.

Tone Decode Time: The acquisition timing of the MTSD-3 is for 750 msec to 1 second A tone. To lengthen the time, increase the value of R-25 or decrease the value of R-25 to decrease the time. R-29 controls the acquisition timing for the B tone and is affected in the same way as R-25.

OPERATION

Decode: Upon decoding of the proper 2-tone sequence the following events will occur:

Momentary Horn Output: The horn output will go low for 3 seconds.

Alert Tone Output: The 2400 Hz alert tone output will generate a tone for 3 seconds.

Transpond Output: The transpond output will go low for 1 second. This is used to activate the PTT of the radio, so that the alert tone will be sent over the air.

Latched +SQ Output: This line will go from +12 VDC to a float condition.

Latched -SQ Output: This line will go from a ground to a float.

Latched Call Output: This line will go from +12 VDC to ground.

Resetting of Latched Outputs:

Power: Cycling the power off and then back on will reset the outputs.

Monitor Input 1: If this input is used, taking the input from a ground, taken high or to a float, and then taking this line back to ground will reset the latched outputs.

TECHNICAL NOTES

2 + 2 Decode: Two MTSD-3 modules can be “anded” together to do 2 + 2 decoding, such as Motorola Quick Call 1 or AvCall. Follow the steps below to set up 2 MTSD-3 modules for 2 + 2 decoding:

1. Lift and isolate the emitter leg of Q3 on the first MTSD-3 from ground.
2. Solder the Horn Output wire (P1-10 Gray/White wire) from the second MTSD-3 to the emitter leg of Q3 on the first MTSD-3.
3. Connect the Horn Output wire (P1-10 Gray/White wire) on the first MTSD-3 to the desired relay or equipment.
4. When both units decode simultaneously the ground path is completed and the Horn Output on Unit 1 goes momentarily (~3 seconds) to ground.

MIDIAN CONTACT INFORMATION

Midian Electronics Inc.

2302 East 22nd Street
Tucson, Arizona 85713 USA

Orders: 1-800-MIDIANS

Phone: 520-884-7981

Fax: 520-884-0422

E-mail: sales@midians.com

Web: <http://www.midians.com/>

- This page intentionally left blank -

NOTE1:
 FREQUENCY RANGE A (STANDARD)
 280 - 1600 Hz
 R9=7.5K, R14=750K, R15=820r
 R7=2.2M, R13 & R16=240K 1%

FREQUENCY RANGE B 500 - 2800 Hz
 R9=4.7K, R14=390K, R15=1K
 R7=1.2M, R13 & R16=120K 1%

REACH TABLE

	SLOW	FAST
R7	1.2M	1.2M
R13	120K	120K
R16	120K	120K
R14	390K	390K
R9	4.7K	4.7K
R25	2.7M	62K
R27	1.8M	560K
R29	360K	33K

MOT. TONE ONLY BATT SAVE
 MOD 1270 ---- A=2.8S B=.8S
 R25=820K - R29=1.1M R30=OMIT
 C6 =2.2uF - C8 =.47uF

SeiCal 2+2 MIN A=B=.6S
 R29=1.1M R30=OMIT C8=.47uF

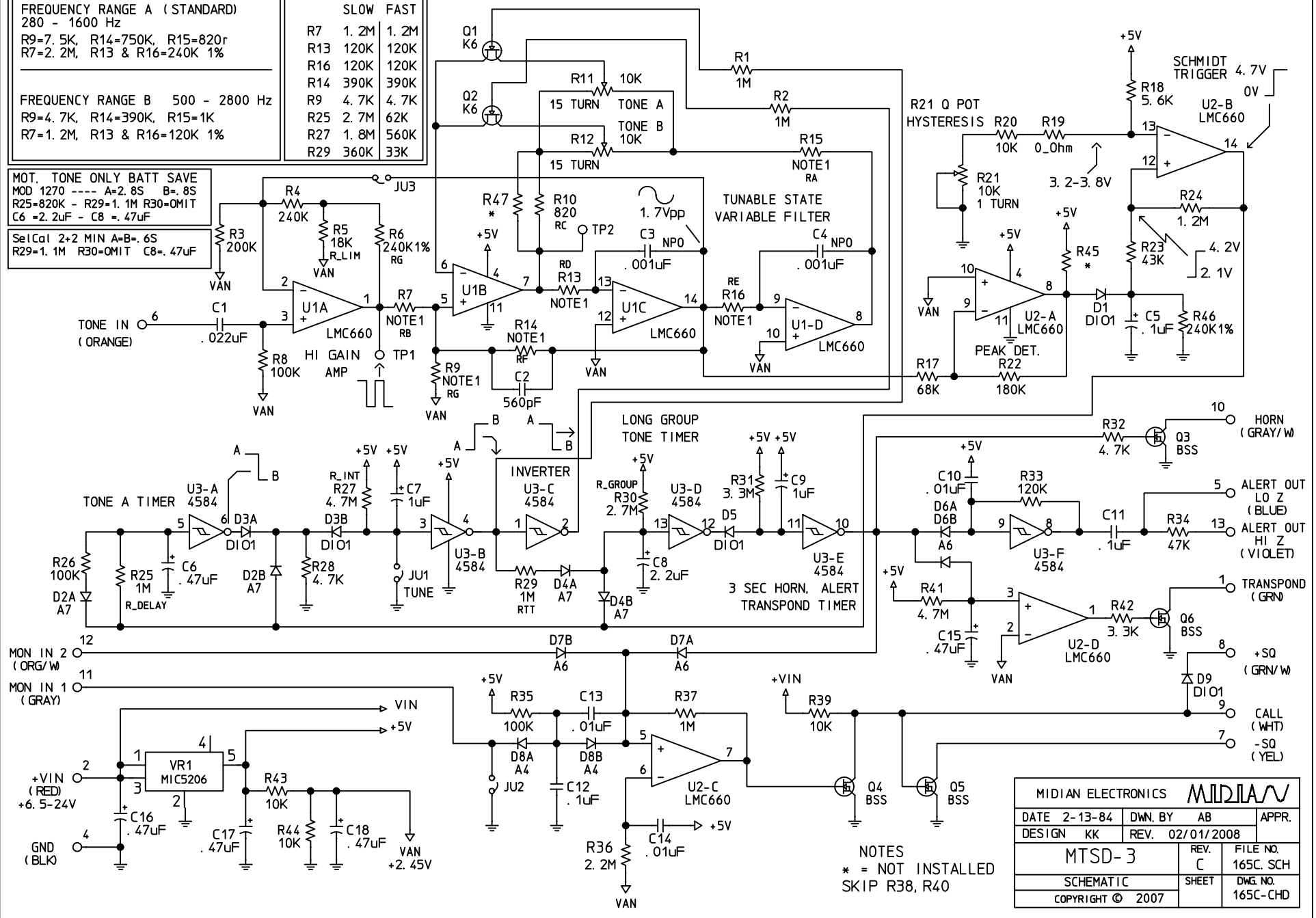

NOTES
 * = NOT INSTALLED
 SKIP R38, R40

MIDIAN ELECTRONICS MIDIAN		
DATE 2-13-84	DWN. BY AB	APPR.
DESIGN KK	REV. 02/01/2008	
MTSD-3		REV. C
SCHEMATIC		FILE NO. 165C. SCH
COPYRIGHT © 2007		SHEET
		DWG. NO. 165C-CHD

- This page intentionally left blank -

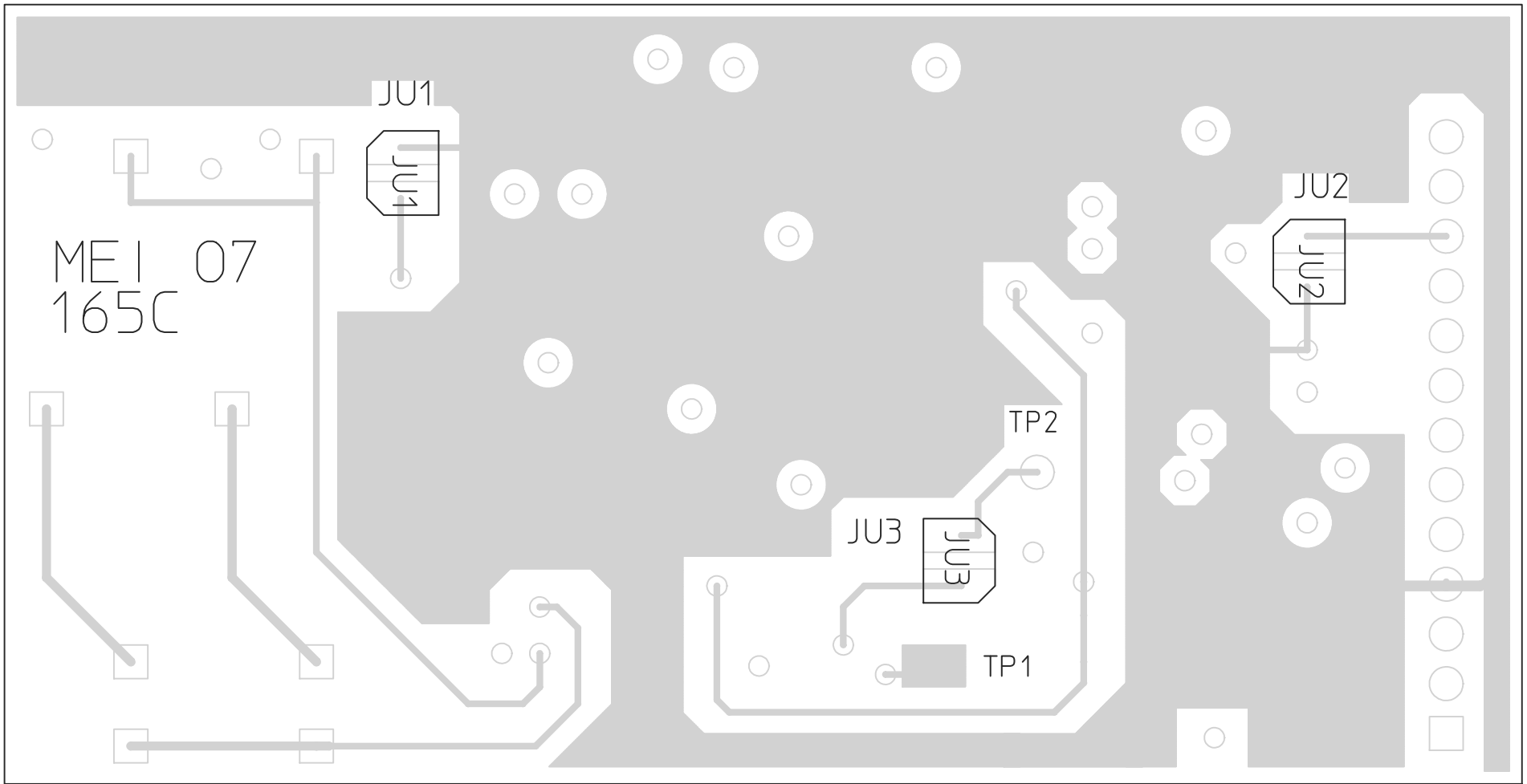

* = NOT INSTALLED

MIDIAN ELECTRONICS		MIDIAN	
DATE	2/13/84	DWN. BY	AB
DESIGN	KK	REV.	02/01/2008
		APPR.	

MTSD-3	REV. C	FILE NO. 165C.SCH
PICTORIAL	ECO -	DWG. NO. 165C-CHP
COPYRIGHT © 2007		