



## TVS-2

### High Level Rolling Code Scrambler

Manual Revision: 2006-07-15

Covers Software Revisions:

TVS-2: 4.93 & Higher

#### SPECIFICATIONS

Operating Voltage	5.5-15 VDC
Operating Current	9 mA
Operating Temperature	-30 - +60 C
Frequency Response	300-2600 Hz
Input Impedance	100 k $\Omega$
Input Level (TX)	0.2-4.0 VPP
Input Level (RX)	0.3-4.0 VPP
Carrier Suppression	65 dB < Peak Voice
Audio Output Impedance	1K $\Omega$ (min)
Encryption Sequences	+40 Trillion
Random Number Generator	64 bits
Sequence Length (est.)	84 billion years

#### INSTALLATION OVERVIEW

1. Test the radio for functionality.
2. Program the radio per the Radio Programming Section of this manual.
3. Install the scrambler into the radio per the Hardware Installation Section of this manual.
4. Program the scrambler per the Product Programming Section of this manual.

\*\*\*Midian is not responsible for any damage/loss resulting from the use of Midian's products.

#### ABOUT THE TVS-2

The TVS-2 is a high-level rolling code scrambler that uses hopping type rolling code encryption for higher security rather than sweeping code type. The scrambler is capable of features such as ANI, ENI, Deadbeat Disable, Spy, and more when using Midian's Kryptic Signaling format with the CAD-300/DDU-300/TRC-300.

#### RADIO PROGRAMMING

For any programming instructions for a particular radio, please consult Midian's application notes for the TVS-2 if available.

#### HARDWARE INSTALLATION

Be certain to follow standard anti-static procedures when handling any of Midian's products. For installation instructions into a particular radio, please consult Midian's application notes for the TVS-2 if available.

##### P1 – Connector Side

**P1-1 – Green** – PTT Input – Disconnect the line coming from the radio's PTT switch. Connect the PTT Input lead to the PTT switch. If you do not break the PTT line the unit must be programmed for common PTT. See P1-9.

**P1-2 – Red** – VIN +5.5-15 VDC – Connect to switched battery point in the radio. Connect to a regulated voltage point in a vehicular radio if engine noise is present on the battery line. Keep this lead as short as possible.

**P1-3 – Brown** – Mode/Code Select – Connect to a momentary or latching switch.

**P1-4 – Black** – Ground – Connect to the nearest ground plane in the radio.

**P1-5 – Blue** – TX Audio In – The TVS-2 must be installed in the TX audio path between the microphone and the insertion point of CTCSS or other tone signaling. Break the TX audio path and connect to the side nearest the microphone.

**P1-6 – Orange** – Emergency Input – When taken to ground the TVS-2 will send an ENI. This input is continually active.

**P1-7 – Yellow** – RX Audio In – The TVS-2 must be installed in the receive audio path after the CTCSS high pass filter and where any tone signaling is picked off. This point needs to be given a constant level; otherwise the trigger will not work. If possible connect to the high-side of the volume control where a constant level is available. Connect to the source of the audio at the break.

**P1-8 – Green/White** – Audio Enable Out - This output is active during whenever the TVS-2 beeps such as when ringing or changing modes. This lead may be used in several different ways. Connect this lead to a point in the radio, which will turn on the radio's speaker power amp, allowing beep tones to be heard. This lead may also be used to supply a ground to one side of the speaker when used in conjunction with the Alert Tone Output (see P2-13). If used in this manner, make sure that the power amp output stage and Q2 will not be damaged (a resistor may be necessary). This lead may also be used to supply a ground to the cathode of an LED which will blink any time the TVS-2 beeps, providing a visual silent indicator. Be sure to use a current limiting resistor if connecting to an LED.

**P1-9 – White** – PTT Out – Connect to the wire removed from the switch mentioned above (see P1-1). PTT Output should be connected even when using common PTT mode. The PTT transistor is rated for 200 mA continuous.

**P1-10 – Gray/White** – RX Audio Out – Connect to side closest to the receiver's speaker driver amplifier at the above mentioned break point (see P1-7). In addition to outputting receive audio, this lead outputs beep tones whenever applicable, such as when the mode switch is pressed. Beep tones are also available on P2-13.

**P1-11 – Gray** - Mode LED Out – If desired, connect to the anode of an LED and the cathode to ground to indicate scramble or clear mode. This output will source up to 15 mA to drive the LED when in scramble mode.

**P1-12 – Orange/White** – TX Audio Out – Connect to the point nearest the modulator at the above-mentioned breakpoint (see P1-5).

**P1-13 – Violet** – COR Input – Connect to a point in the radio receiver squelch circuit that changes state when carrier is present. A radio whose squelch circuit gives a logic low (0V) or logic high (5V) should be used to drive the COR input. The COR input lead must be connected in order to use Advanced and Standard Mute functions.

## **P2 – Non-Connector Side**

**P2-1** – Keypad Column 3 Input

**P2-2** – Keypad Column 2 Input. Can also be used with a binary switch to select security codes.

**P2-3** – Keypad Column 1 Input

**P2-4** – Keypad Row 4 Input

**P2-5** – Keypad Row 3 Input

**P2-6** – Keypad Row 2 Input. Can also be used with a binary switch to select security codes.

**P2-7** – Keypad Row 1 Input

**P2-8** – Program Input – Connect this lead to the green clip lead from the KL-3 programmer.

**P2-9** – Squelch/Disable Output – When used as Squelch Output, this lead can be used to mute the radio's audio power amplifier by the scrambler. Using this lead to mute the radio is optional since the scrambler can mute internally. When programmed as Disable Output, this output will be active when the disable command is transmitted from the CAD-300/DDU-300/TRC-300 and will remain active until re-enabled from the CAD-300/DDU-300/TRC-300.

**P2-10** – Program Output – Connect this lead to the yellow clip lead from the KL-3 programmer.

**P2-11** – Trunking Delay Input – This input should be used in trunked radios with a channel acquisition strobe output. When used, the TVS-2 will wait up to 5 seconds for a channel to be acquired. After 5 seconds the PTT must be reset. If this input is not used, program the trunk delay polarity to positive and leave unconnected.

**P2-12** – Keypad Ground

**P2-13** – Alert Tone Output - This lead outputs beep tones whenever applicable, such as when the TVS-2 rings or the mode is changed. This lead should be used when the Audio Enable Output is insufficient for turning on the radio's audio amplifier. This lead should be connected directly to the high side of the radio's speaker. If neither side of the speaker is connected to ground, the Audio Enable Output may be used to supply a ground to the speaker when tones are being output. Be sure this will not damage the radio's audio amplifier or Q2.

## HARDWARE ALIGNMENT

1. For level reference, take a signal measurement at the input and output of the RX audio path's breaking point component by modulating the receiver with a full quieting signal and at full modulation. That's 5 kHz for a wide band radio and 2.5 kHz for a narrow band radio of a 1 KHz tone.
2. For the TX signal level, speak normally into the microphone while monitoring the TX breaking point. For a higher level, say "FOUR" and document the levels. If it is possible to inject a 1 kHz tone into the microphone stage, set that as 3 kHz for wide band or 1.5 kHz for narrow band as a reference.
3. To set up the RX level correctly on the TVS-2 (after installation into the radio), modulate the radio receiver at full quieting with a 1250 Hz tone at 1.0 to 1.2 kHz for wide band or .4 to .6 kHz for narrow band.
4. To adjust the RX input pot, monitor with a DC scope at IC-6 Pin 7 until it triggers at the step 3 levels.
5. Adjust the RX output pot to match the reference level documented from step 1 output level. If the output level cannot be obtained call Midian for further details.
6. For the TX levels, set the TX input pot so that the level at IC-9 Pin 1 is just below clipping by speaking loudly into the microphone with the TVS-2 in scramble mode.
7. With the TVS-2 in the clear mode, adjust the TX output pot for the documented level from step 2 output level.

For further details for aligning the RX and TX lines, refer to the TVS-2 detailed service manual.

## PRODUCT PROGRAMMING

Midian's TVS-2 is programmed via Midian's KL-3 programming cable. Please reference the KL-3 manual for setup instructions of the KL-3 software and hardware. From the product selection screen on the KL-3 UP software, select the TVS-2 from the list and click OK.

Set the parameters of the TVS-2 software to fit the application. If any clarifications on a feature are

required, move the mouse cursor over the feature name until the question mark appears and right click, a definition of the feature will be shown.

After entering the parameters, save the file by going to File - Save As. Enter the file name in the File Name block and click Save. Saving the file will allow for quick and easy reprogramming of units.

**KL-3 Programming:** Only the Black and Green KL-3 leads need to be connected to the TVS-2 for product programming. Connect the green KL-3 lead to P2-8 on the TVS-2 and the black KL-3 to a common ground. With power on to the scrambler, click ProgramUnit! in the KL-3 UP software.

**KL-3 Reading:** The Yellow KL-3 lead, along with the Black and Green leads, is required for reading the unit. Connect the yellow KL-3 lead to P2-10 on the TVS-2. With power on to the scrambler, click ReadUnit! in the KL-3 UP software.

After programming or reading the TVS-2 turn off the scrambler for 3 seconds and then turn back on.

**Important Note:** Do not attempt to 'clone' the scrambler by reading one and then programming another. When the scrambler is read, the security codes will be read out as zeroes. If another scrambler is then cloned with this information, the scramblers will be incompatible because they have different security codes. To ensure scramblers communicate with each other, program them from a saved *file*.

## OPERATION

### Mode Select:

**Momentary Switch:** When using a momentary switch, pressing and then releasing the switch will cause the scrambler to switch modes. A medium tone followed by a high tone indicates the scrambler has been switched into scrambled mode. A medium tone followed by a low tone indicates the scrambler has been switched into clear mode.

**Latched Switch:** When using a latched switch, pressing the switch will toggle the mode. Depending on the programmed polarity will determine the mode. For example if the polarity is programmed as low, then the scrambler will be in scrambled mode when taken to ground. No mode indication tones are available.

**Code Select:**

**Momentary Switch:** When using a momentary switch, pressing and holding the switch will toggle the scrambler through the programmed codes (1-4 codes). The scrambler will emit a number of tones corresponding to the code that is being switched to. When the desired code is reached simply release the switch.

**Latched Switch:** Multi-code operation is not available when using a latched switch.

**TECHNICAL NOTES**

**Radio Compatibility:** Midian has taken the utmost care to ensure the option board integrates into the radio with minimal impact to the features of the radio. However, some features may not be available in the radio when an option board is used. If a feature is not available, please contact Midian to see if the feature can be added.

**MIDIAN CONTACT INFORMATION**

Midian Electronics Inc.  
2302 East 22<sup>nd</sup> Street  
Tucson, Arizona 85713 USA

Orders: 1-800-MIDIANS  
Phone: 520-884-7981  
Fax: 520-884-0422  
E-mail: [sales@midians.com](mailto:sales@midians.com)  
Web: <http://www.midians.com/>

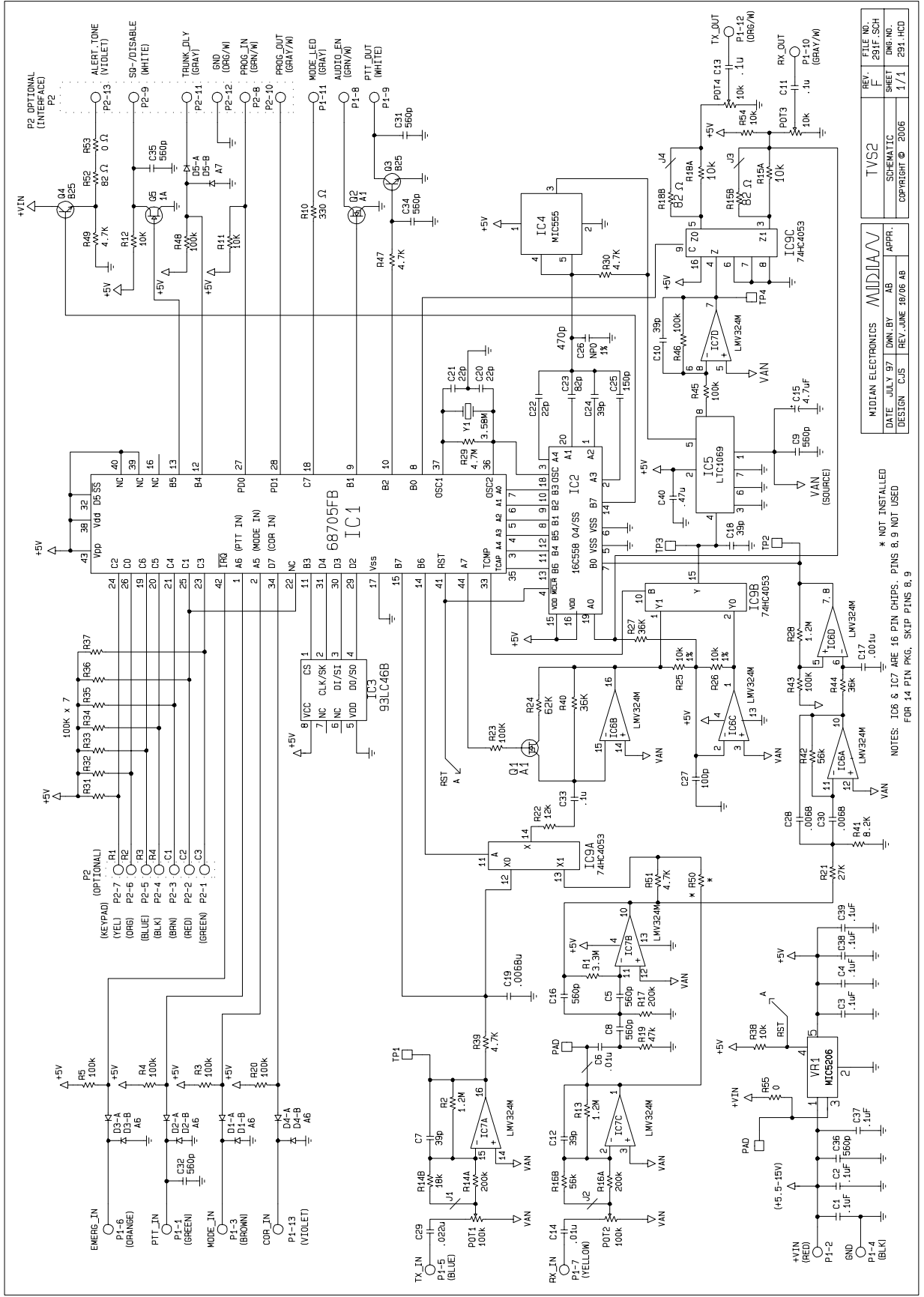

REV.	F	FILE NO.	
SHEET	1/1	DWG. NO.	291-SCH
DATE	JULY 97	DESIGNER	CJS
APPR.	AB	DATE	JUNE 19/06 AB
SCHEMATIC	TVS2	COPYRIGHT	© 2006

MIDIAN ELECTRONICS  
 \* NOT INSTALLED  
 F09 14 PIN PKG. SKIP PINS 8, 9  
 NOTES: IC6 & IC7 ARE 16 PIN CHIPS. PINS 8, 9 NOT USED

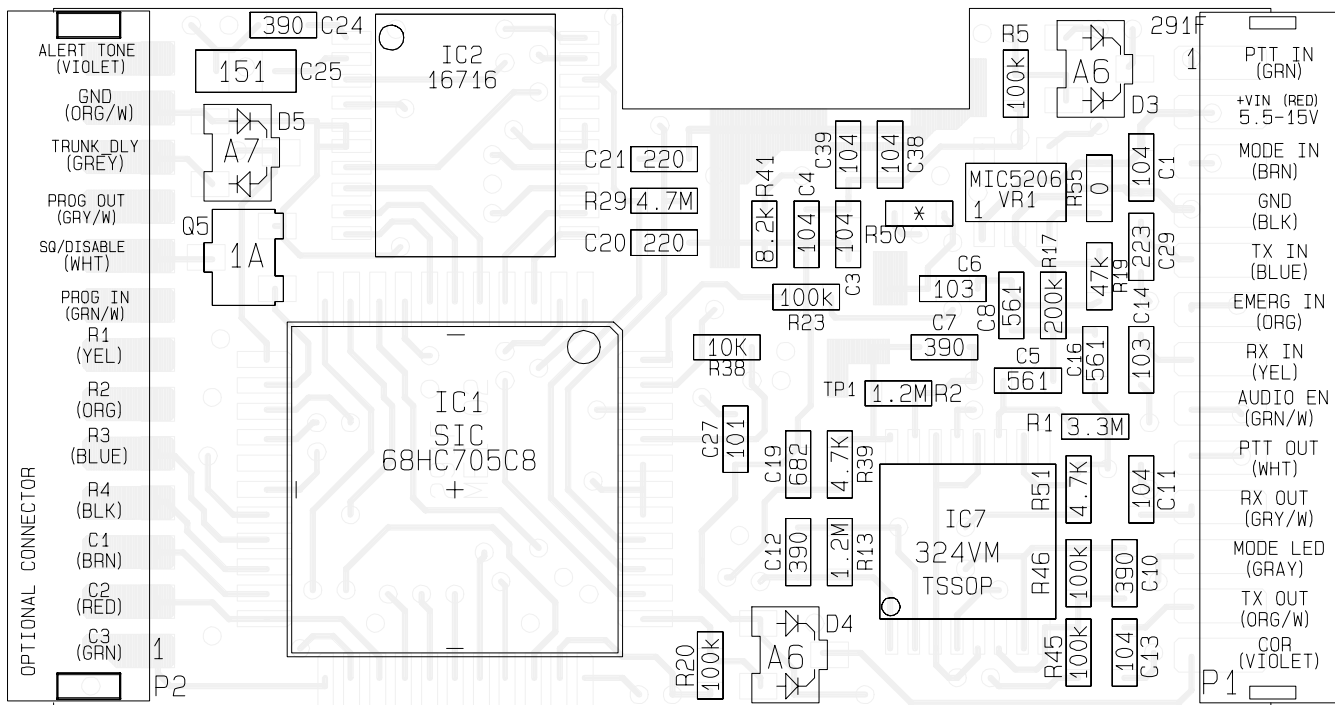

\* NOT INSTALLED

TVS2 COMP

UPDATED JUNE 18/06 AB

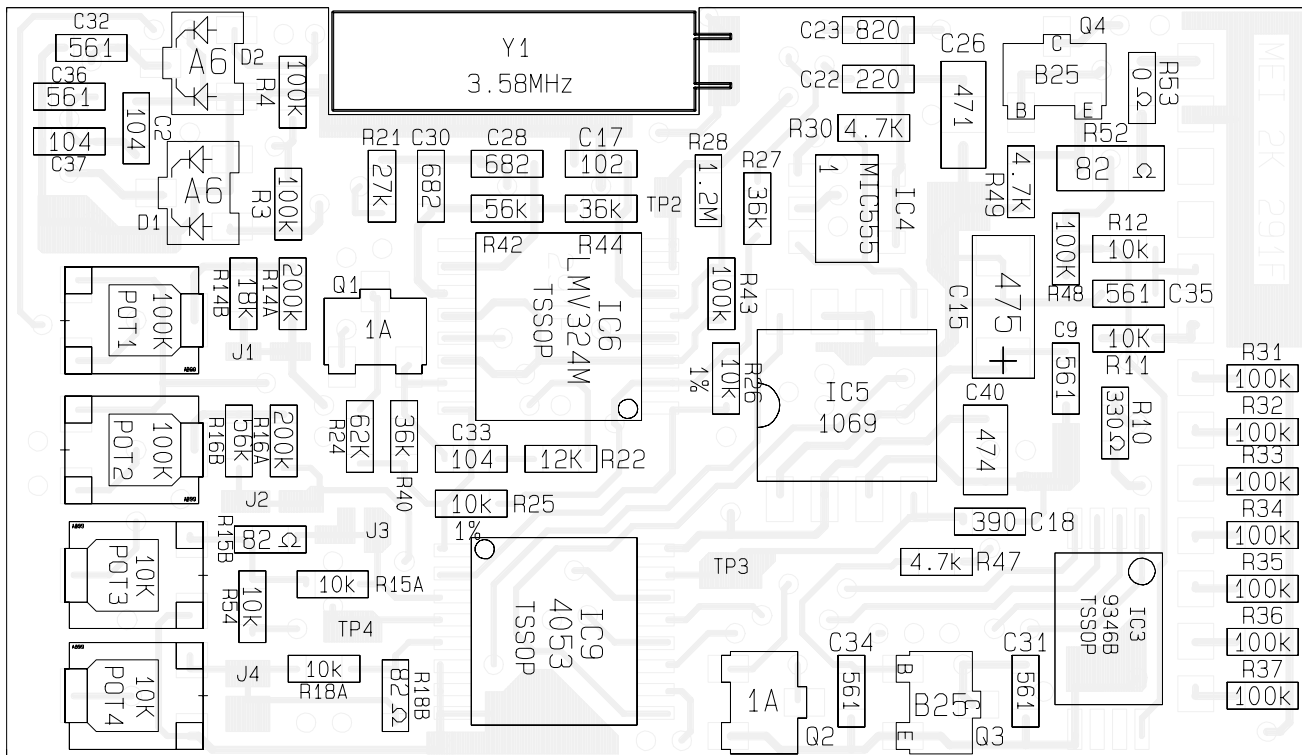

\* NOT INSTALLED

MIDIAN ELECTRONICS		<b>MIDIAN</b>	
DATE JULY 97	DWN.BY AIB	APPR.	
DESIGN CJS	REV. JUN 18/06 AB		

TVS2		REV. F	FILE NO. 291F.PCB
PICTORIAL		SHEET	DWG. NO. 291-HCP
COPYRIGHT © 2006			