



VPU-12A

16-Code Voice Inversion Scrambler

Manual Revision: 2007-10-29

Covers Software Revisions:
VPU-12A: 3.0 and higher

SPECIFICATIONS

Operating Voltage	+3.7-15 VDC
Operating Current	3.5 mA
Operating Temperature	-30 - +60 C
Frequency Response – 2100 Hz	300-1700 Hz
Frequency Response – 3100 Hz	300-2500 Hz
Frequency Response – 4100 Hz	300-3600 Hz
Audio Output Impedance	<10KΩ
Input Level	150-1000 mV p-p
Input Impedance	>60KΩ
Frequency Error	<0.25%
Device Gain or Loss	Unity
Inversion Frequency Range	2100 – 4100 Hz
Number of Inversion Codes	16

GENERAL INFORMATION

Midian's VPU-12A voice inversion scrambler provides an entry level of voice security for two-way radio communications. The VPU-12A provides up to 16 different inversion frequencies that are selectable using 4-line binary. These inversion frequencies are programmable using Midian's KL-3. The VPU-12A is compatible with Midian's VPU-12, but adds the benefit of mode indications.

PRODUCT PROGRAMMING

The VPU-12A comes preprogrammed with default inversion frequencies (see Table 1 below). By configuring the 4-line binary outputs, the desired inversion frequency can be selected. Other default features are a Power-Up State of Clear, a Mode Select of Momentary and a Mode Polarity of Active Low. If different parameters are needed, the KL-3 programming cable and software will be needed.

Table 1

Grounded Wires – Frequency Select (A, B, C, D)	Binary	Code #	Inversion Frequency (Hz)
Org/Wht, Gray, Gray/Wht, Grn/Wht	0000	1	2100
Org/Wht, Gray, Gray/Wht	0001	2	2341
Org/Wht, Gray, Grn/Wht	0010	3	2423
Org/Wht & Gray	0011	4	2587
Org/Wht, Gray/Wht, Grn/Wht	0100	5	2632
Org/Wht, Gray/Wht	0101	6	2728
Org/Wht, Grn/Wht	0110	7	2868
Org/Wht	0111	8	2976
Gray, Gray/Wht, Grn/Wht	1000	9	3023
Gray, Gray/Wht	1001	10	3107
Gray, Grn/Wht	1010	11	3333
Gray	1011	12	3388
Gray/Wht, Grn/Wht	1100	13	3500
Gray/Wht	1101	14	3729
Grn/Wht	1110	15	4096
None	1111	16	3276

The VPU-12A is programmed using the KL-3. Please reference the KL-3 manual for setup of the KL-3 hardware and software.

Set the parameters of the VPU-12A to fit the application. If any clarifications on a feature are required, move the mouse cursor over the feature name until the question mark appears and right click, a definition of the feature will be shown.

After entering the parameters, save the file by going to File – Save As. Enter the file name in the File Name block and click Save. Saving the file will allow for quick and easy reprogramming of units.

Connect the Blue wire to the Green KL-3 lead and the Black wire to a common ground with the KL-3's Black lead. The Yellow clip lead is connected to the brown wire for reading the product.

To program the VPU-12A, apply power to the unit and click "Program Unit" in the menu bar. To read the VPU-12A, apply power to the unit and click "Read Unit" in the menu bar.

HARDWARE INSTALLATION

Be certain to follow standard anti-static procedures when handling any of Midian's products.

P1-4 – Black – Ground – Connect to the nearest ground point.

P1-2 – Red - +3.7 – 15 VDC – Connect to switched B+ in the radio.

P1-6 – Orange – RX Input – Connect after the CTCSS high-pass filter in radios using CTCSS or DCS. Failure to do so will cause the CTCSS to be inverted from a low to a high frequency. Other signaling tones that might be used on the system should be decoded before the scrambler input. The audio path should be broken with this lead connected to the break point closest to the discriminator.

P1-13 – Violet – RX Output – Connect to the break point described in the RX Input on the side closest to the speaker.

P1-9 – White – TX Input – Connect to the radio modulator circuit before the insertion point for CTCSS or other tone signaling. The audio path is broken and this lead is connected to the break point closest to the microphone.

P1-1 – Green – TX Output – Connect to the break point described in TX Input on the side closest to the modulator.

P1-7 – Yellow – PTT Input – Selection of the RX or TX path is provided via this lead. A ground from the PTT switch will select TX & releasing the ground will select RX.

P1-3 – Brown – Mode Input/Program Out – Connect to a momentary or latched switch for selection of scramble or clear modes. For program out, connect this lead to the yellow clip lead from the KL-3.

P1-5 – Blue – Program In – Connect this wire to the green clip lead from the KL-3.

P1-8 – Green/White – Frequency Select A – Frequency select A, B, C and D are used to determine the selected inversion frequency (see Table 1 above).

P1-10 – Gray/White – Frequency Select B – Frequency select A, B, C and D are used to determine the selected inversion frequency (see Table 1 above).

P1-11 – Gray – Frequency Select C or Mode LED – Frequency select A, B, C and D are used to determine the selected inversion frequency (see Table 1 above).

When used for Mode LED install R-34 and remove D4. Connect this wire to the cathode of the LED and connect the anode of the LED to V+. The Mode LED output provides an active low.

P1-12 – Orange/White – Frequency Select D or Audio Enable – Frequency select A, B, C and D are used to determine the selected inversion frequency (see Table 1 above).

When used for Audio Enable install R-36 and remove D-3. Connect this wire to a point in the radio that when grounded turns on the audio amplifier.

Mode LED: If the frequency select lines are being used for inversion frequency selection, the Mode LED hole can have a wire added. Connect this wire to the cathode of the LED and connect the anode of the LED to V+. The Mode LED output provides an active low.

Audio Enable: If the frequency select lines are being used for inversion frequency selection the Audio Enable hole can have a wire added. Connect this wire to a point in the radio that when grounded turns on the audio amplifier.

RADIO PROGRAMMING

The VPU-12A is a generic module that wires into most radios. Any radio specific programming, if available, would be found on any Application Notes available for those radios. You may visit our website or call us for application notes.

HARDWARE ALIGNMENT

The VPU-12A is a unity gain device. If for some reason more or less gain is needed adjust R-2, R-12, R-18 or R-19 as needed. For the TX Input, Midian recommends having 1 V p-p at Pin 1 of IC-5. Adjusting R-2 will adjust the level at Pin 1 of IC-5.

For the RX Input, Midian recommends having 1 V p-p at Pin 7 of IC-5. Adjusting R-12 will adjust the level at Pin 7 of IC-5.

For the TX Output, Midian recommends matching the level of the radio that is present at the TX Input (P1-9).

For the RX Output, Midian recommends matching the level of the radio that is present at the RX Input (P1-6).

OPERATION

Mode Selection: The mode of the VPU-12A can be controlled by a momentary or latched switch.

Latched Switch: Programming the VPU-12A to latched with a Mode Polarity of +/- will cause the scrambler to be in clear mode when high and scramble mode when taken to ground. A Mode Polarity of -/+ will cause the scrambler to be in clear mode when taken to ground and scramble mode when high.

Momentary Switch: Programming the VPU-12A to momentary with a Mode Polarity of +/- will cause the scrambler to toggle modes when taken to ground. A Mode Polarity of -/+ will cause the scrambler to toggle modes when taken high.

Code Selection:

Single Code: If only a single inversion frequency is desired connect the frequency select lines to ground as indicated in Table 1 above. Otherwise if no frequency select lines are grounded code 16 will be selected.

Multi-Code: The VPU-12A has a 4-line binary input that can be used to select from 16 different inversion frequencies (see Table 1 above).

TECHNICAL NOTES

Pre-emphasis/De-emphasis: The scrambler should be installed before pre-emphasis and after de-emphasis.

If installed after pre-emphasis and before de-emphasis, the recovered audio may be noisier due to the amplification of the noise.

If installed before pre-emphasis and before de-emphasis, recovered audio will be de-emphasized (bassy).

If installed after pre-emphasis and after de-emphasis, recovered audio is pre-emphasized (tinny).

MIDIAN CONTACT INFORMATION

Midian Electronics Inc.

2302 East 22nd Street
Tucson, Arizona 85713 USA

Orders: 1-800-MIDIANS

Phone: 520-884-7981

Fax: 520-884-0422

E-mail: sales@midians.com

Web: <http://www.midians.com/>

- This page intentionally left blank -

- This page intentionally left blank -

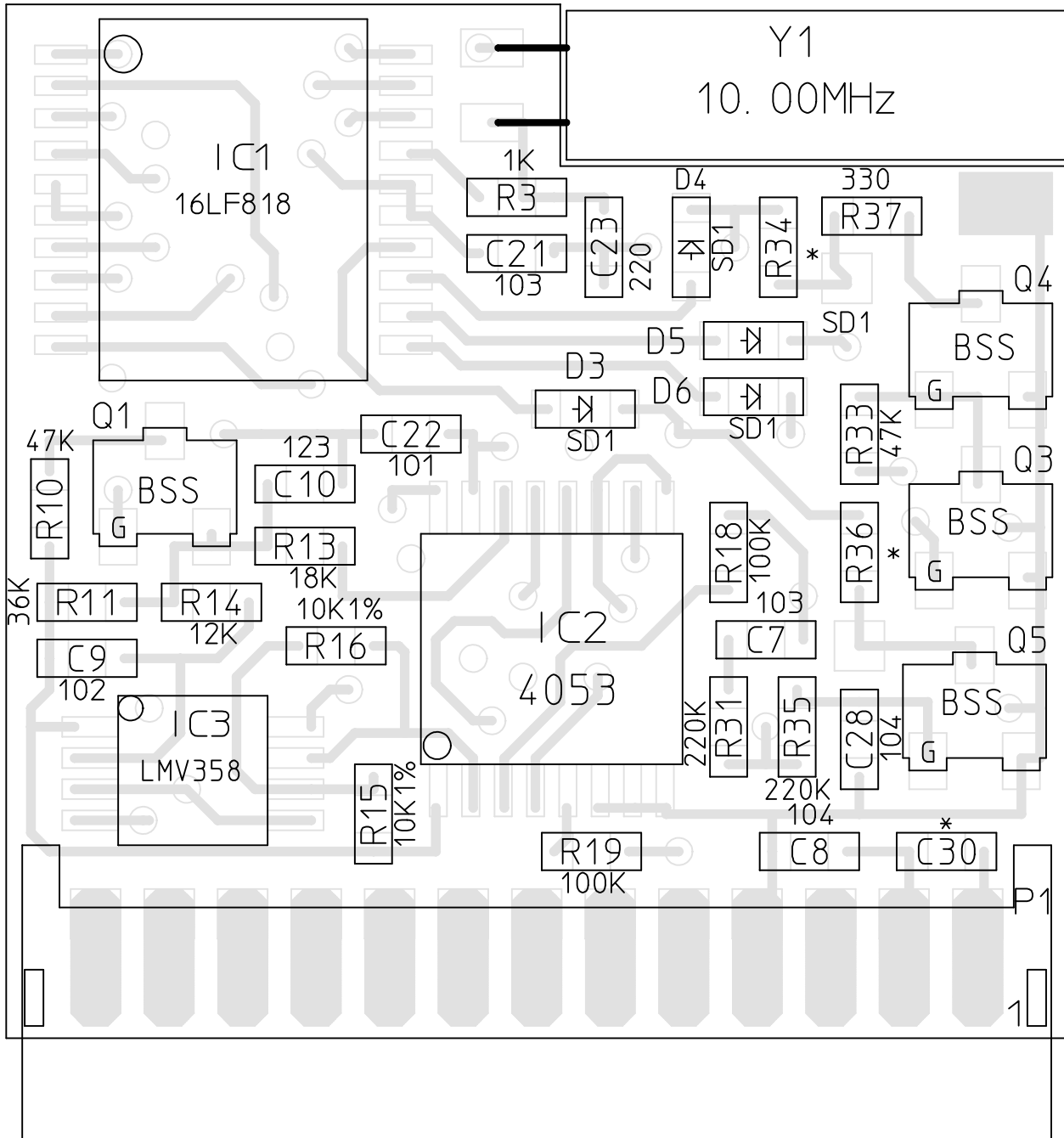

MIDIAN ELECTRONICS			MIDIAN		VPU- 12A		REV. A- 1	FILE NO. 361_A1.PCB
DATE 7/ 2007	DWN. BY AB	APPR.	PICTORIAL			SHEET	DWG. NO. 361.HCD	
DESIGN CJS	REV. OCT/30/07 AS		COPYRIGHT © 2007					

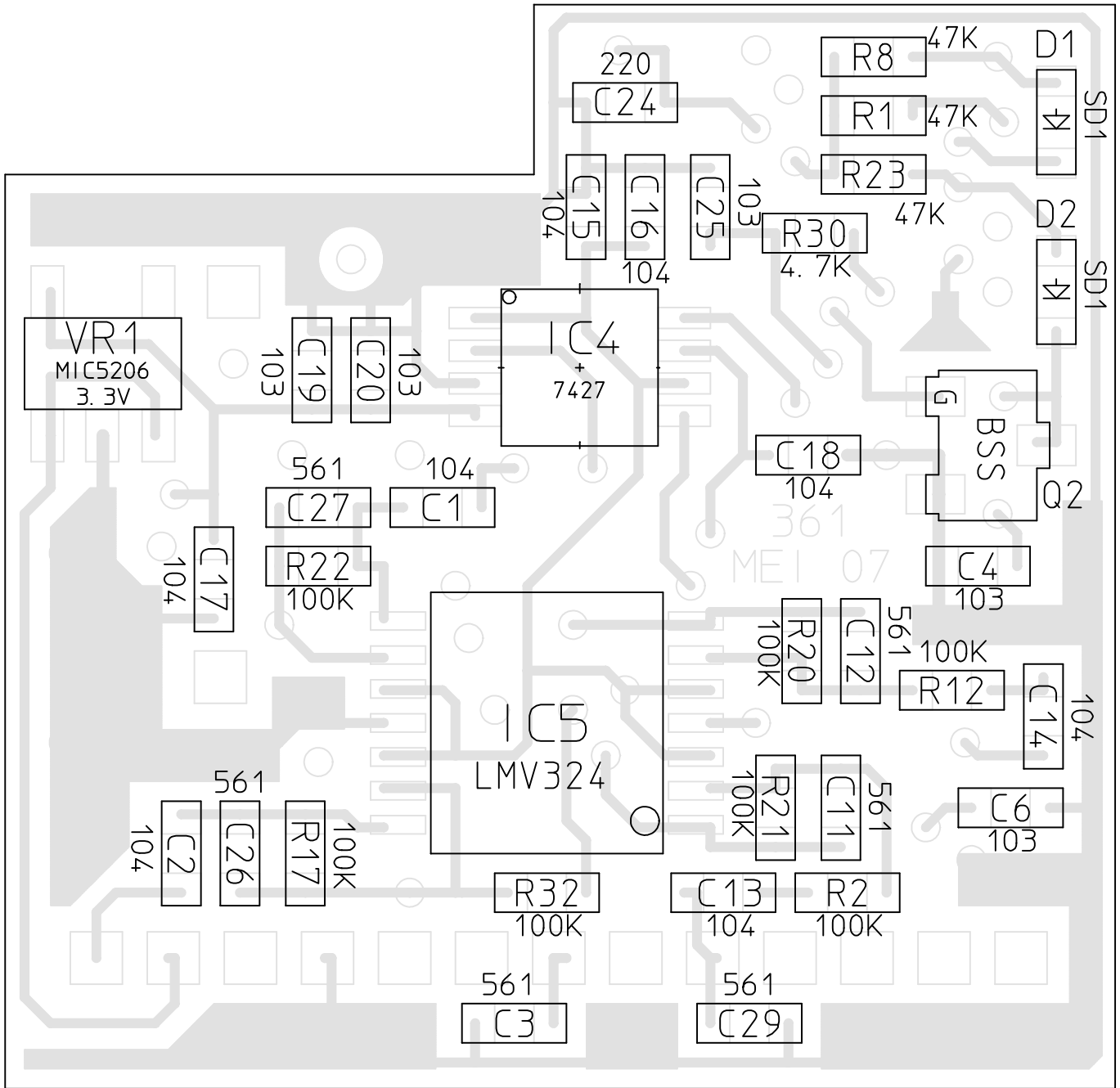

MIDIAN ELECTRONICS		MIDIAN		VPU-12A		REV. A-1	FILE NO. 361_A1.PCB
DATE 7/2007	DWN. BY AB	APPR.	PICTORIAL		SHEET	DWG. NO. 361.HCD	
DESIGN CJS	REV. OCT/30/07 AS		COPYRIGHT © 2007				